

# Installation and Operation Manual

## Remote Weld Bench

Models RWB-2000 and RWB-3000

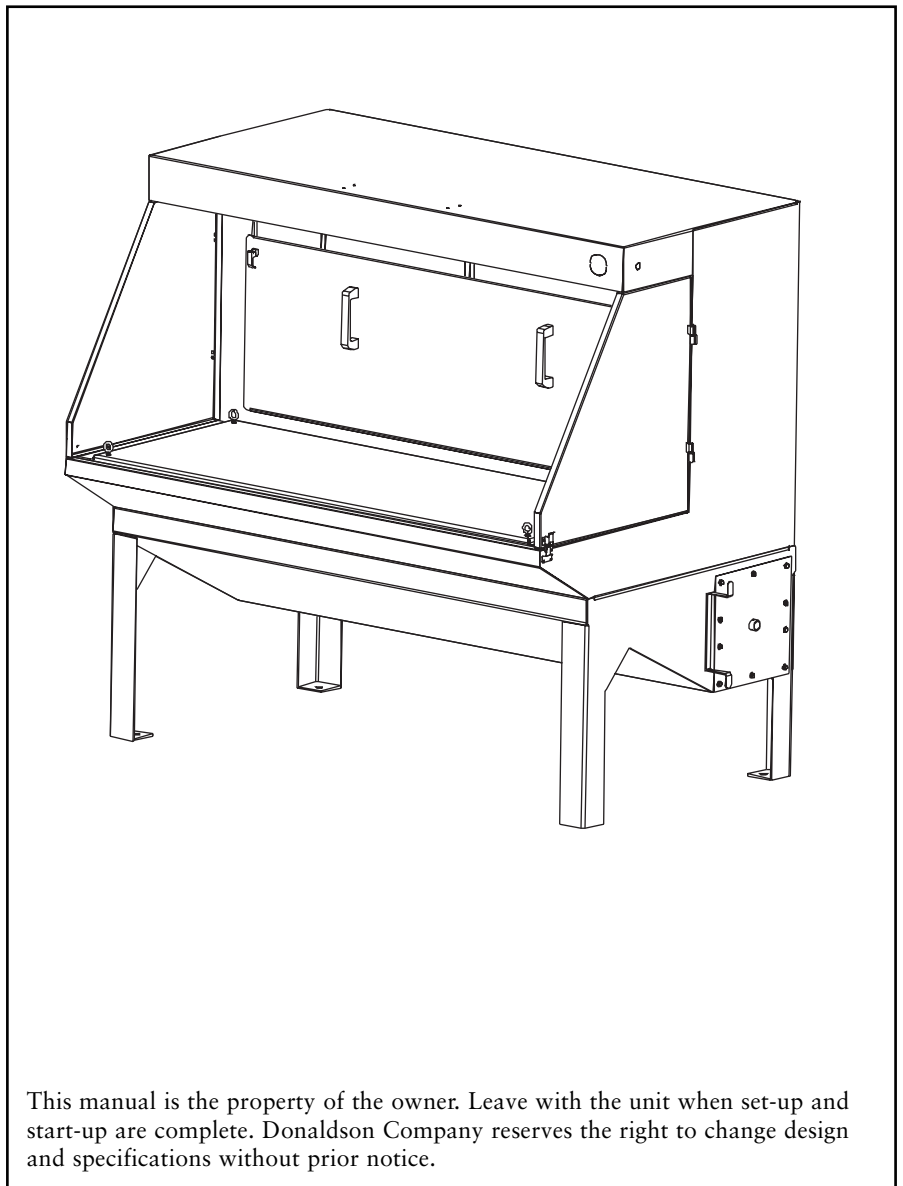

Throughout this manual, statements indicating precautions necessary to avoid equipment failure are referenced in a Note. Statements indicating potential hazards that could result in *personal injury* or *property damage* are referenced in a Caution! box.

This manual is the property of the owner. Leave with the unit when set-up and start-up are complete. Donaldson Company reserves the right to change design and specifications without prior notice.



## **Caution!**

### **Application of Dust Control Equipment**

- Combustible materials such as buffing lint, paper, wood, aluminum or steel dust, weld fume, or flammable solvents represent fire or explosion hazards. Use special care when selecting and operating all dust or fume collection equipment when combustible materials are present to protect workers and property from damage due to fire and/or explosion. Consult and comply with National and Local Codes relating to fire or explosion and all other appropriate codes when determining the location and operation of dust or fume collection equipment.
- When combustible materials are present, consult with an installer of fire extinguishing systems familiar with these types of fire hazards and local fire codes for recommendations and installation of fire extinguishing and explosion protection systems. Donaldson dust collection equipment is not equipped with fire extinguishing or explosion protection systems.
- DO NOT allow sparks, cigarettes or other burning objects to enter the hood or duct of any dust or fume control equipment as these may initiate a fire or explosion.
- For optimum collector performance, use only Donaldson replacement parts.

**Table of Contents**

Introduction . . . . .	5	Figure 1, Typical Installation . . . . .	4
Operational Explanation . . . . .	5	Figure 2, Operational Schematic . . . . .	5
Normal Operation . . . . .	5	Figure 3, Light Fixture and Eye Bolt . . . . .	7
Installation . . . . .	6	Figure 4, Scheduled Maintenance . . . . .	8
Inspection . . . . .	6		
Ship Loose Items . . . . .	6		
Preinstallation . . . . .	6		
Assembly of Standard Equipment . . . . .	6		
Sprinkler Coupling . . . . .	6		
Collar Pack . . . . .	7		
Backdraft Panel . . . . .	7		
Swing Door . . . . .	7		
Optional Industrial Light Fixture . . . . .	7		
Work Surface Grounding . . . . .	7		
Service . . . . .	8		
Scheduled Maintenance . . . . .	8		
Troubleshooting Guide . . . . .	9		
Warranty . . . . .	12		



This manual contains specific precautionary statements relative to worker safety. Read thoroughly and comply as directed. Discuss the use and application of this equipment with a Donaldson representative. Instruct all personnel on safe use and maintenance procedures.

**Data Sheet**

Model Number _____	Serial Number _____
Ship Date _____	Installation Date _____
Customer Name _____	
Address _____	
_____	
Filter Type _____	
Accessories _____	
Other _____	

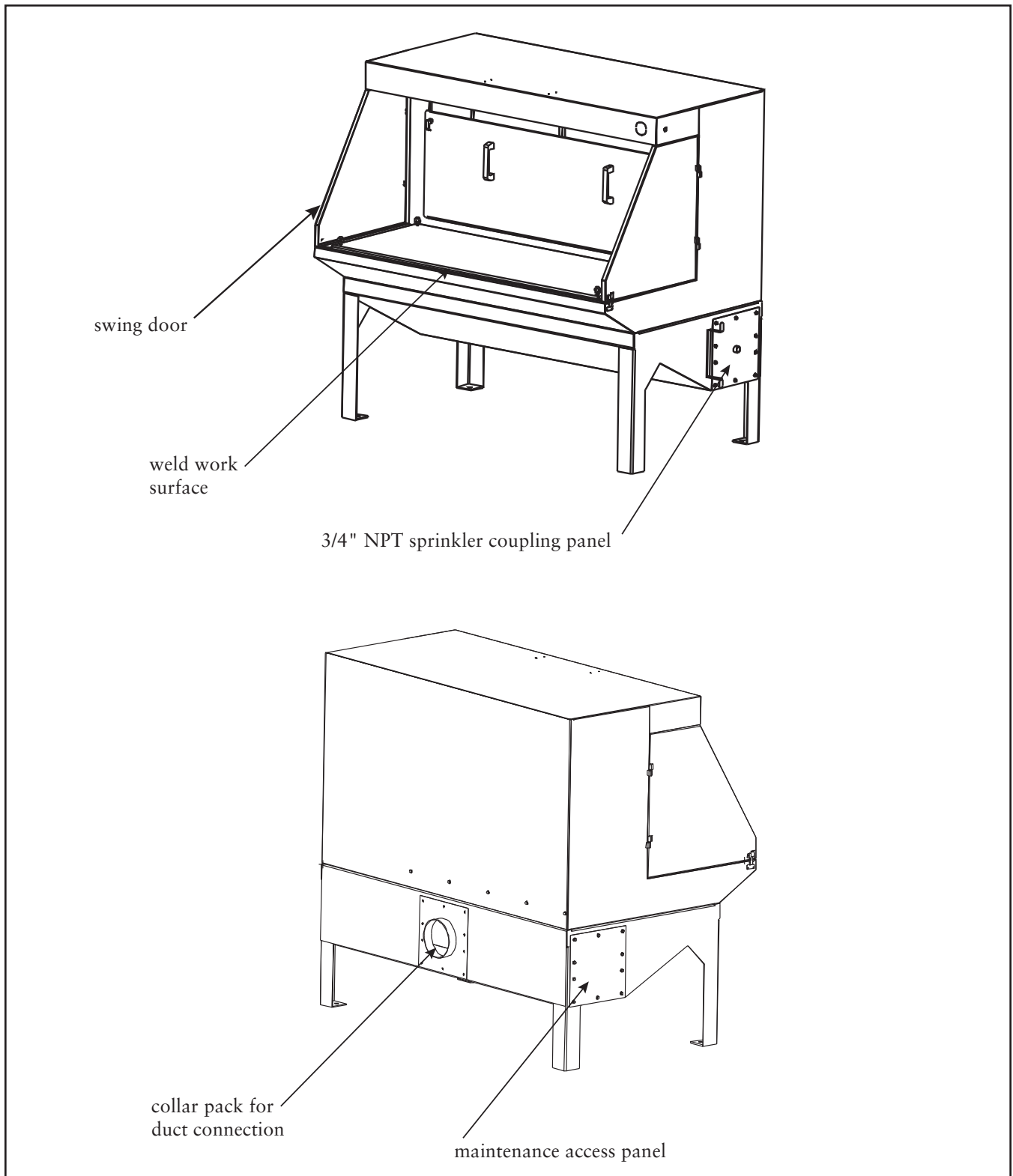

Figure 1, Typical Remote Weld Bench Installation

## Introduction



### CAUTION!

- Misuse or modification of this equipment may result in personal injury.
- Do not misuse or modify.

The Remote Weld Bench is an optional accessory for dust collection systems. Standard models are the RWB-2000, which is a 2000 cfm unit for use with 2000 cfm dust collectors, and the RWB-3000, a 3000 cfm unit for use with 3000 cfm dust collectors. Technical and field support are always available from your local Donaldson Representative and distributors.

**Important:** OSHA may have requirements regarding recirculating filtered air back into your facility. Consult with the appropriate local authorities to ensure compliance with all applicable codes.

## Operational Explanation

### Normal Operation

During normal operation, the contaminated or fume-laden air enters the Remote Weld Bench through the backdraft. The fume-laden, incoming air goes through the collar pack, which is ducted to the dust collector. See Figure 2, Operational Schematic. The dust collector that the Remote Weld Bench is ducted to should have a flame retardant filter media which can reduce the risk of fire hazard.

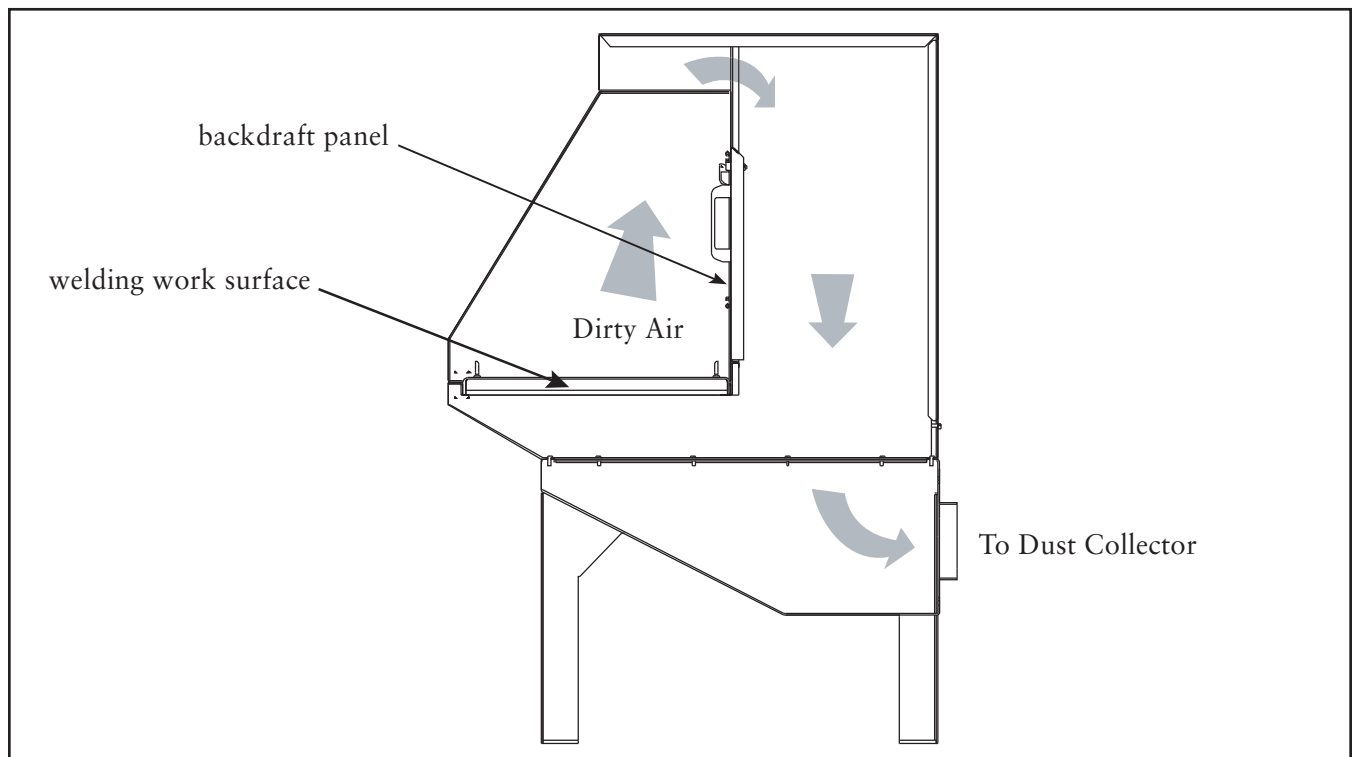

Figure 2, Operational Schematic

## Installation

### Inspection

The RWB-2000 and RWB-3000 are normally shipped by common carrier and should be carefully inspected for damages that may occur en route. Any damage should be noted and the carrier notified immediately.

### Ship Loose Items

Items shipped loose with the Remote Weld Bench may include:

- Remote Weld Bench Installation and Operation Manual, IOM 9421701.

### Preinstallation

**Note:** See Specification Control Drawing for footprint dimensions, weights, and any other load information.

The standard Remote Weld Bench is delivered completely assembled. See the Specification Control Drawing for footprint dimensions and weights. The total weight of the unit should include auxiliary equipment and other live loads.

Remove all crating, strapping, wrap and securing hardware from both outside and/or inside the unit. Check the parts received with the packing slips. If parts are missing or damaged, notify the carrier and your local Donaldson representative immediately.

The welding work surface is seven gauge hot rolled steel. A waterborne, corrosion-resistant clear film has been applied to the work surface. Remove this film by washing the work surface with a detergent cleaner and then drying with a cloth before welding.

**Note:** *DO NOT* weld without removing the corrosion-resistant film. Oily residue will be generated if the film is not removed.

### Assembly of Standard Equipment (See Figure 1)

Each Remote Weld Bench is shipped fully assembled from the factory. The RWB-2000 weighs approximately 600-lbs. The forklift must be able to safely lift the unit. The Remote Weld Bench standard collar pack is factory installed in the back of the unit. The collar pack can be relocated to either side of the hopper by switching it with either the maintenance access panel or the 3/4" NPT sprinkler coupling panel. See Figure 1, Typical Remote Weld Bench Installation.

### Sprinkler Coupling

A 3/4" NPT pipe coupling is located on the right-hand side of the hopper. It is used to attach a sprinkler head if necessary. Check your local codes for sprinkler requirements. See Figure 1, Typical Remote Weld Bench Installation.



#### **CAUTION!**

Use care in selecting the installation location for dust collection equipment and follow all appropriate national and local fire codes.

**Note:** Donaldson equipment does not include fire prevention equipment, all sprinkler heads must be supplied by others.

### *Collar Pack*

The RWB-2000 has three collar pack sizes; 8, 10, and 12-inch ID. The RWB-3000 has two collar pack sizes; 10 and 12-inch ID. Make sure to use the proper duct system inlet to connect to the collar pack.

### *Backdraft Panel*

The Remote Weld Bench backdraft panel is removable by turning the lift and turn latches and pulling the panel forward. Use the handles to remove the panel. This feature allows the customer to clean the dirty section of the unit. The dirty air section should be initially cleaned after every 8-12 hours of operation. When welding on oily parts, cleaning may be required daily to remove any oily buildup to minimize risk of fire.

### *Swing Door*

Each Remote Weld Bench has a right and left, lift-off swing door. This feature accommodates long and awkward workpieces. When working on small pieces, the swing doors should be closed to capture all contaminants.

### *Optional Industrial Light Fixture (See Figure 3)*

When the optional light fixture is ordered, the light switch and cord are factory installed. Fluorescent bulb must be supplied by customer.

### *Work Surface Grounding*

The welding work surface is grounded by eye bolts (two for RWB-2000 and four for RWB-3000) that are screwed into the welding work surface. Please refer to your welding supply operation manual.

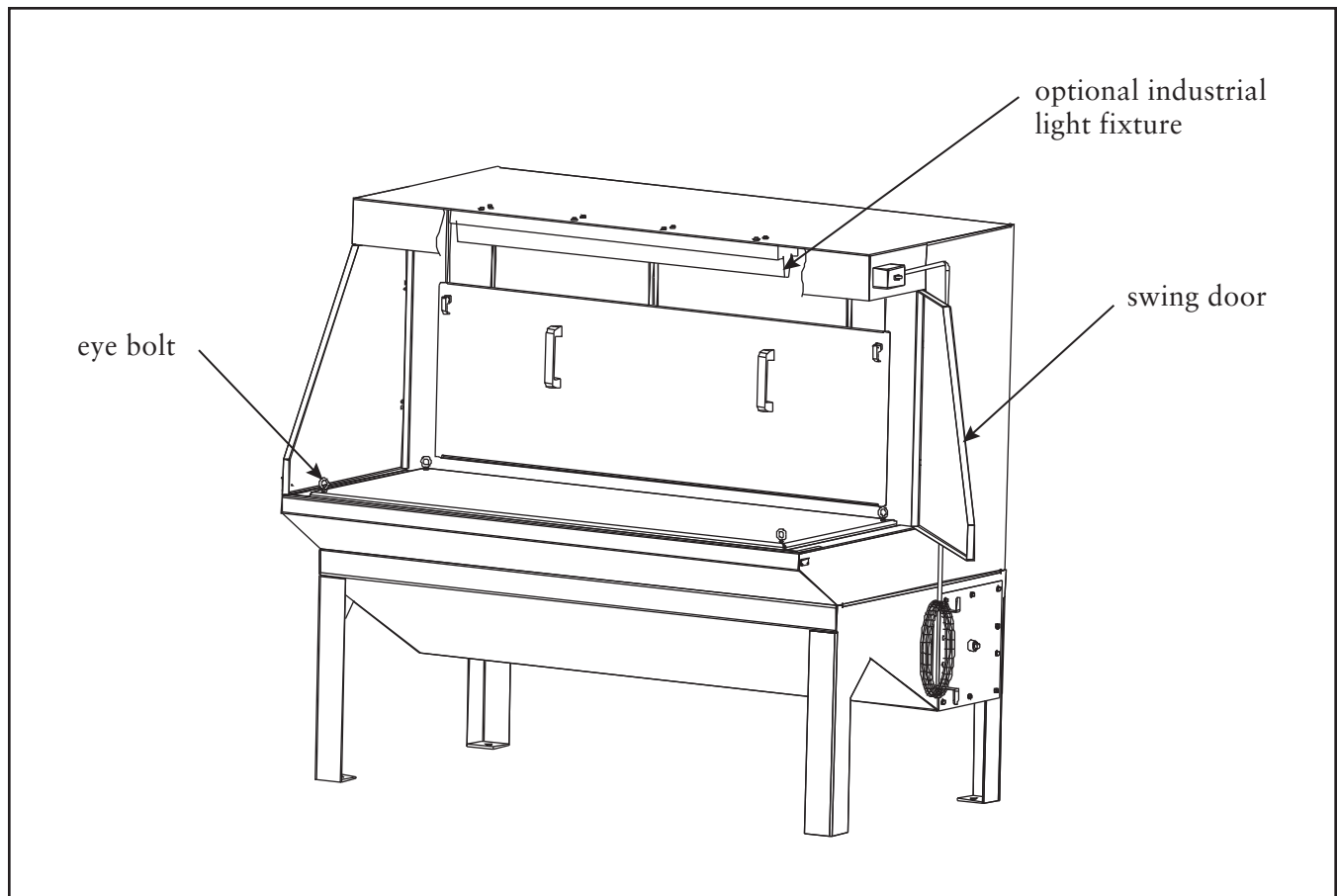
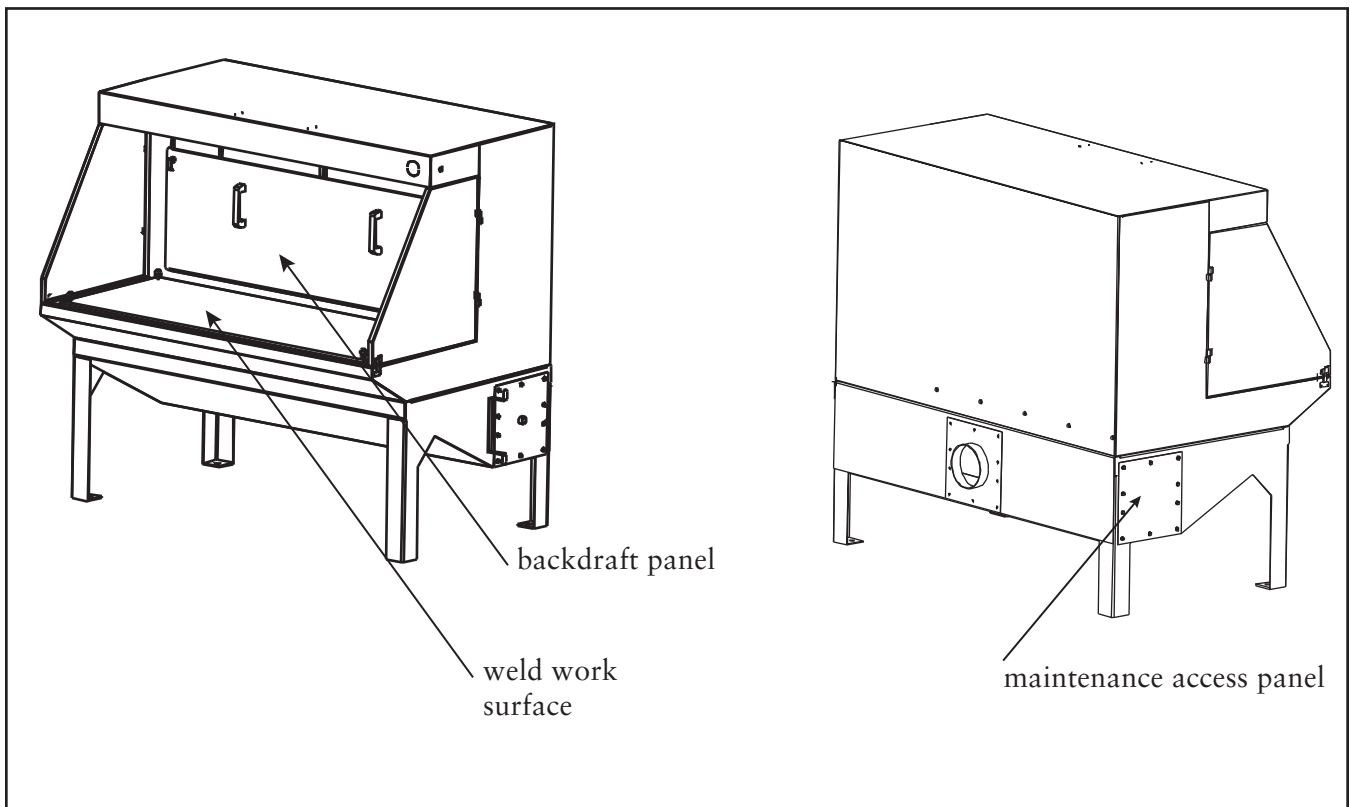

*Figure 3, Light Fixtures and Eye Bolt*

## Service

### Scheduled Maintenance (See Figure 4)

1. Remove the welding work surface by lifting at the eyebolts. See Figure 4, Scheduled Maintenance.
2. Remove the backdraft panel. See Backdraft Panel Section.
3. Remove the maintenance access panel.
4. Use dry sweeper or brush to clean the back wall and inside of hopper. Depending on the fume or dust properties, a putty knife may be used. Dispose of contaminants properly.
5. Reinstall welding work surface, maintenance access panel, and backdraft panel.
6. Regular dust removal in the maintenance schedule can reduce the risk of fire hazard.
7. The Remote Weld Bench should be cleaned every 8 to 12 hours of operation.



*Figure 4, Scheduled Maintenance*



## Troubleshooting

Trouble	Possible Cause	Remedy
Insufficient airflow	1. Fan not working	
	a. Incorrect fan	When adding the Remote Weld Bench to an existing dust collection system, make sure the duct system is capable of handling the losses and the remote bench pressure losses.
	b. Incorrect damper setting	Check dampers for correct positioning.

**This Page Intentionally Left Blank**



## Limited Warranty

Donaldson® warrants to the original purchaser that the major structural components of the goods will be free from defects in materials and workmanship for ten (10) years from the date of shipment, if properly installed, maintained and operated under normal conditions. Donaldson warrants all other Donaldson built components and accessories including Donaldson Airlocks, TBI Fans, TRB Fans, Fume Collector products and Donaldson built Afterfilter housings for twelve (12) months from date of shipment. Donaldson warrants Donaldson built filter elements to be free from defects in materials and workmanship for eighteen (18) months from date of shipment. Donaldson does not warrant against damages due to corrosion, abrasion, normal wear and tear, product modification, or product misapplication. Donaldson also makes no warranty whatsoever as to any goods manufactured or supplied by others including electric motors, fans and control components. After Donaldson has been given adequate opportunity to remedy any defects in material or workmanship, Donaldson retains the sole option to accept return of the goods, with freight paid by the purchaser, and to refund the purchase price for the goods after confirming the goods are returned undamaged and in usable condition. Such a refund will be in the full extent of Donaldson's liability. Donaldson shall not be liable for any other costs, expenses or damages whether direct, indirect, special, incidental, consequential or otherwise. The terms of this warranty may be modified only by a special warranty document signed by a Director, General Manager or Vice President of Donaldson. Failure to use genuine Donaldson replacement parts may void this warranty. **THERE EXIST NO OTHER REPRESENTATIONS, WARRANTIES OR GUARANTEES EXCEPT AS STATED IN THIS PARAGRAPH AND ALL OTHER WARRANTIES INCLUDING MERCHANTABILITY AND FITNESS FOR A PARTICULAR PURPOSE, WHETHER EXPRESS OR IMPLIED ARE HEREBY EXPRESSLY EXCLUDED AND DISCLAIMED.**

## Parts and Service

For genuine Donaldson Donaldson replacement filters  
and parts, call the Parts Express Line

**800-365-1331 USA**

**800-343-3639 within Mexico**

**[www.donaldsonorit.com](http://www.donaldsonorit.com)**

For faster service, have unit's model and serial number, parts number,  
description, and quantity available.



**Donaldson**<sup>®</sup>  
*Filtration Solutions*

Donaldson Company, Inc.  
Industrial Air Filtration  
P.O. Box 1299  
Minneapolis, MN 55440-1299  
[dustmktg@mail.donaldson.com](mailto:dustmktg@mail.donaldson.com)

Donaldson Company, Inc. is the leading designer and manufacturer of dust, mist, and fume collection equipment used to control industrial air pollutants. Our equipment is designed to help reduce occupational hazard, lengthen machine life, reduce in-plant maintenance requirements, and improve product quality.