

# Installation and Operation Manual

## Pulse Jet Filters

Models FSD, VSD, FTD, VTD, FSDC, VSDC, FTP, RSD, RTD,  
RTP



Throughout this manual statements indicating precautions necessary to avoid equipment failure are referenced in a **Note**. Statements indicating potential hazards that could result in *personal injury* or *property damage* are referenced in a **CAUTION!** box.

*Illustrations are for reference only, as actual product may vary.*



This manual is property of the owner. Leave with the unit when set-up and start-up are complete. Donaldson Company reserves the right to change design and specifications without prior notice.



## **CAUTION!**

### **Application of Dust Control Equipment**

- Combustible materials such as buffing lint, paper, wood, aluminum or steel dust, weld fume, or flammable solvents represent fire or explosion hazards. Use special care when selecting and operating all dust or fume collection equipment when combustible materials are present to protect workers and property from damage due to fire and/or explosion. Consult and comply with National and Local Codes relating to fire or explosion and all other appropriate codes when determining the location and operation of dust or fume collection equipment.
- When combustible materials are present, consult with an installer of fire extinguishing systems familiar with these types of fire hazards and local fire codes for recommendations and installation of fire extinguishing and explosion protection systems. Donaldson Torit dust collection equipment is not equipped with fire extinguishing or explosion protection systems.
- DO NOT allow sparks, cigarettes or other burning objects to enter the hood or duct of any dust or fume control equipment as these may initiate a fire or explosion.
- For optimum collector performance, use only Donaldson Torit replacement parts.

## Contents

Introduction.....4  
 Shipping and Receiving .....4  
 Installation.....6  
 Operation.....9  
 Maintenance .....9  
 Timer Programming .....10  
 Troubleshooting.....10  
 Order Form.....11  
 Warranty.....16

Magnehelic® is a registered trademarks of Dwyer Instruments, Inc.



This manual contains specific precautionary statements relative to worker safety. Read thoroughly and comply as directed. Discuss the use and application of this equipment with a Donaldson Torit representative. Instruct all personnel on safe use and maintenance procedures.

## Data Sheet

Model Number \_\_\_\_\_ Serial Number \_\_\_\_\_  
 Ship Date \_\_\_\_\_ Installation Date \_\_\_\_\_  
 Customer Name \_\_\_\_\_  
     Address \_\_\_\_\_  
     \_\_\_\_\_

Filter Type \_\_\_\_\_  
 Accessories \_\_\_\_\_  
     Other \_\_\_\_\_

## INTRODUCTION

Thank you for purchasing a Donaldson Torit pulse jet filter. Your new Donaldson filter is built to the highest industry standards. Great care has been taken to design and manufacture a high quality, low maintenance product that is economical to use and maintain.

This manual is intended to assist in the installation, operation and maintenance of your filter. The instructions in this manual are general in nature and apply to a variety of models. Each situation dictates the need for any special precautions and it is the user's responsibility to ensure that adequate safety measures are employed in installation, operation and maintenance. As always, follow good safety practices around all equipment.

## SHIPPING AND RECEIVING

Donaldson filters are shipped as completely assembled as transportation allows. Upon arrival inspect all components for damage that may have occurred during shipping. Check the bill of lading or packing list to verify the proper equipment and quantities. Should any discrepancies arise contact the carrier immediately.

All filters are equipped with lifting ears on the plenum (top) section. Nylon straps with clevis- es should be attached to all four lift ears and lifted using appropriate lifting equipment (i.e. crane). Units that are partially assembled should be off loaded using appropriate lifting equipment (i.e. crane, forklift) using nylon strapping and or wooden blocks to prevent damage to the filter.



### CAUTION!

- Misuse or modification of this equipment may result in personal injury.
- Do not misuse or modify.

## INSTALLATION

Filter units may require engineered footings and/or foundations. Prior to installation of filter consult local building codes for footing requirements.

### Preassembled Units

Filter units that arrive fully assembled can be lifted directly into final position. Anchor bolts should be installed and tightened before lifting equipment is disconnected from filter. All bolt connections should be checked and retightened if necessary.

Connect all ducting using RTV-silicone between all mating flanges. Connect compressed air supply line to manifold header. Compressed air must be clean, dry, oil-free and regulated. Maximum air pressure is 100 psi. Electrical connections will vary with options (see electrical next page).

Connect Magnehelic Gauge per diagram on next page. Install bags and cages per diagram on next page.

### Partially assembled Units

The degree of assembly upon arrival may vary on some units. The following steps are typical for assembling a filter.

- 1) Place hopper on level surface with product discharge flange up ( i.e. upside down)
- 2) Attach legs and cross braces with supplied hardware. Note: Leg is mounted on the in side of the hopper corner mounts.
- 3) Using appropriate lifting equipment (i.e. crane) right the hopper and leg assembly and lift into final position. Secure to foundation. Check all connections, retighten if necessary.
- 4) Right bag section if not already in righted position. Place a bead of RTV silicone on the top flange.
- 5) Lift tubesheet into position. Side door model tubesheets have venturis, top door models do not. Venturis point down into the bag section. Place a bead of RTV silicone on the top of the tube sheet.

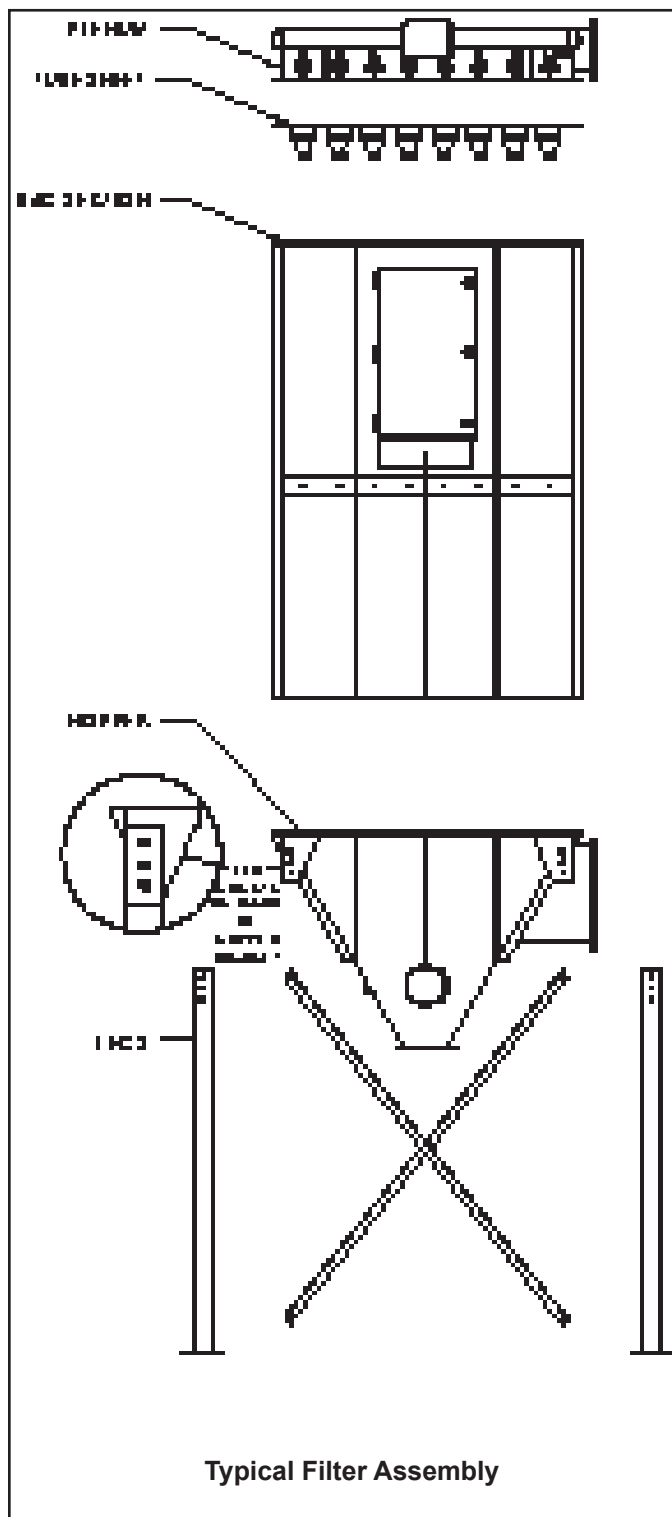

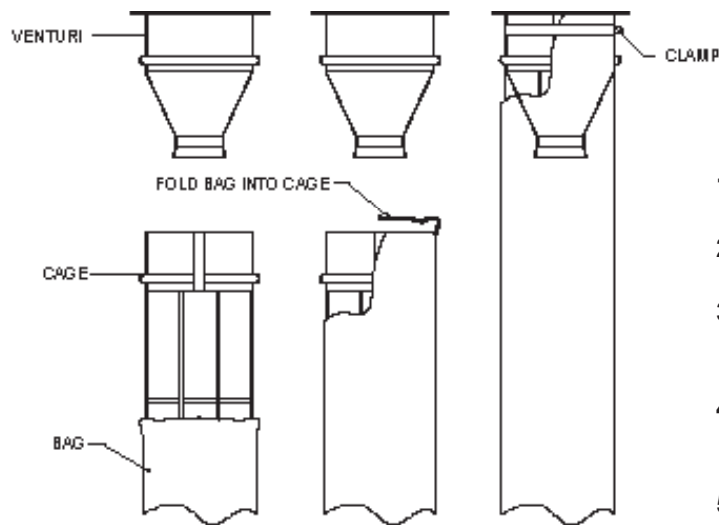

- 1) Slide cage into bag.
- 2) Fold bag into top of cage.
- 3) Slide loose clamp over bag just above detent.
- 4) Slide bag and cage over venturi until detent seats.
- 5) Tighten clamp.

**FSD AND VSD BAG INSTALLATION**  
VSDC CARTRIDGE FILTERS HAVE INTEGRAL CAGES

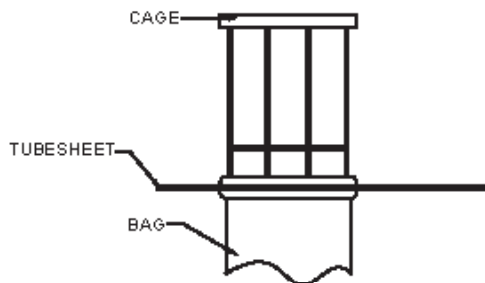
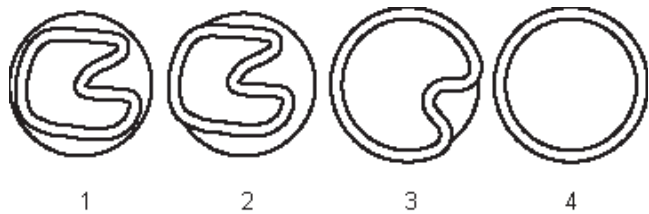

- 1) Slip end of bag into tubesheet.
- 2) Fold bag collar snap band into center.
- 3) Align groove in collar with edge of tubesheet.
- 4) Release collar guiding it along edge.
- 5) Press on collar to snap into final position.
- 6) Slide cage into bag

**FTD AND VTD BAG INSTALLATION**

- 6) Lift plenum into position. Secure to bag section using supplied hardware. All bolts should be in place and tightened before attempting to lift plenum and bag section assembly. Top door models also have perimeter railing on the plenum section. Do **not** attempt to lift the plenum by the railing.
- 7) Place a bead of RTV silicone on the top hopper flange. Lift plenum/bag section assembly into position and install all hardware. Do not disconnect lifting equipment until all bolts are in place and tightened.
- 8) Follow instructions for preassembled units on previous page.
- 9) Install bags and cages or cartridges. On FSD and VSD models slip cage into bag and fold top of bag into cage then place loosened clamp over bag and cage. Slide bag, cage and clamp or cartridge and clamp onto venturi. Position clamp above venturi detent and tighten.

On FTD and VTD models slip bag through top of tubesheet and snap top band into place. Slide cage into bag making sure that cage top lip covers bag collar.

Cartridge filters are installed by sliding the element through the tubesheet and seating the edge of the tubesheet into the groove of the rubber collar. A steel snap band is then placed on the inside of the rubber collar.

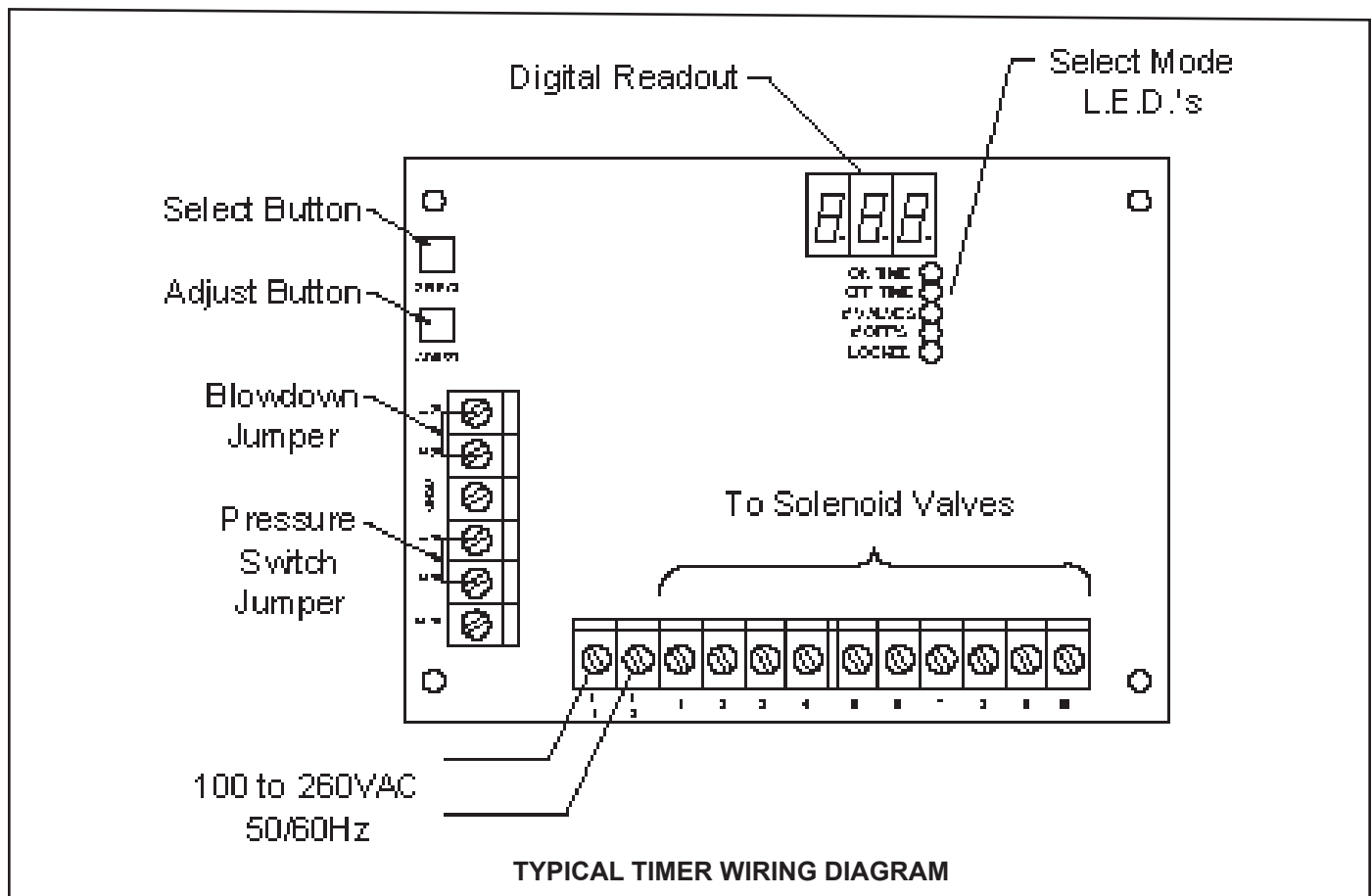
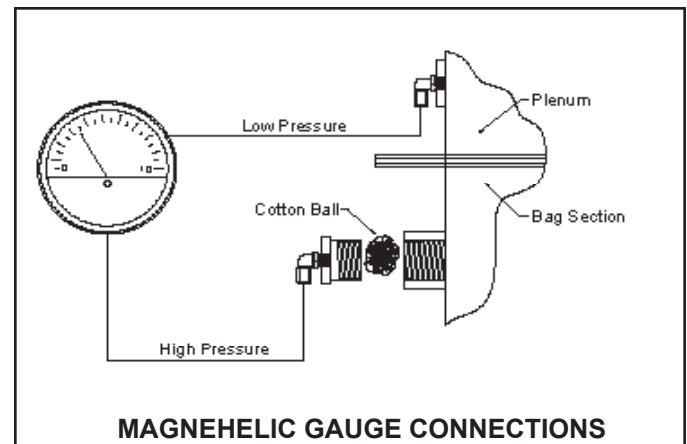

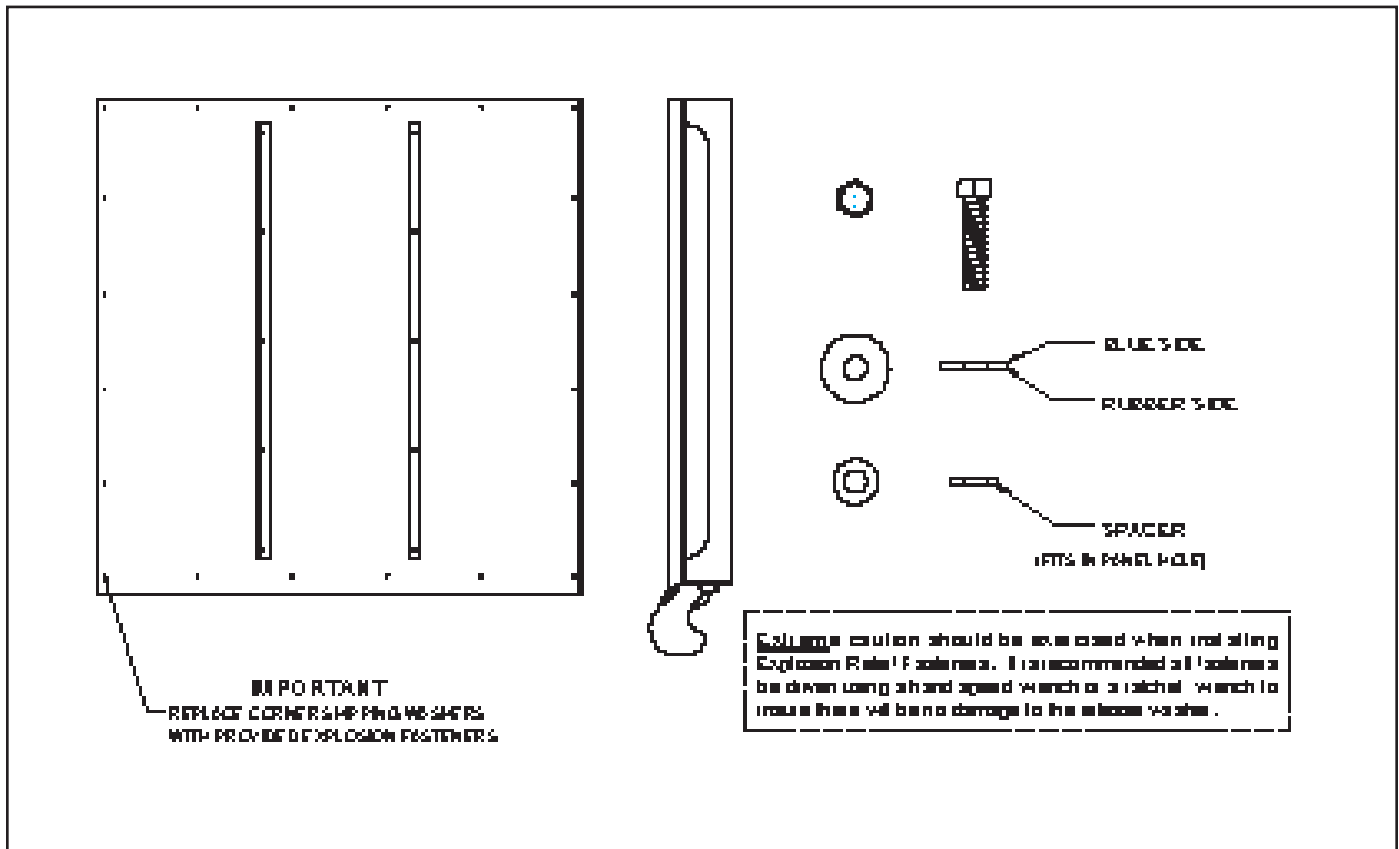
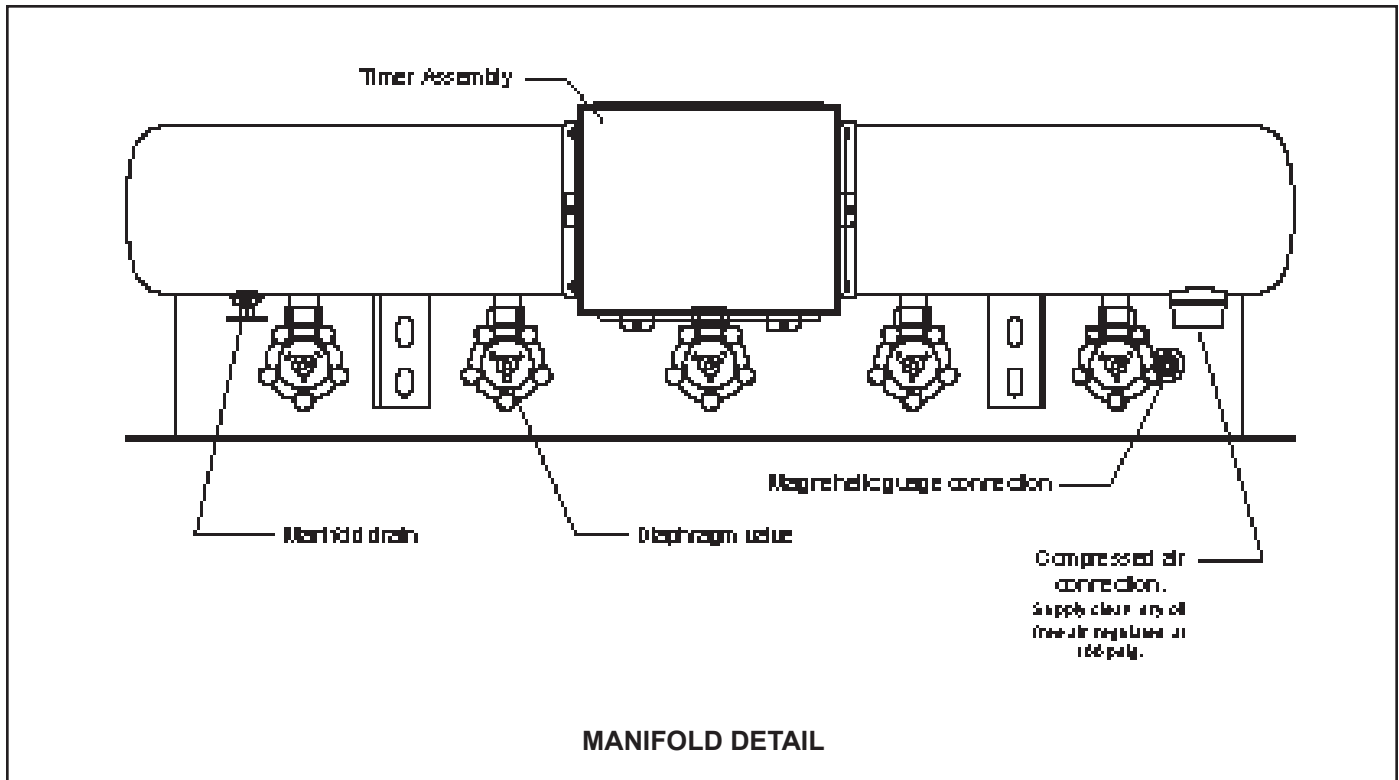



**Start up Sequence - Typical**

- 1) Start rotary airlock (if applicable)
- 2) Start timer/sequencer.
- 3) Start blower.
- 4) Start process equipment.

**Shut down Sequence - Typical**

- 1) Stop process equipment. Allow filter to continue operating for 10-15 minutes.
- 2) Stop blower. Allow airlock and timer to continue running for 10-15 minutes.
- 3) Stop timer and air lock.

**OPERATION****Pre-Start-Up Checklist**

- All bolt connections tightened.
- All electrical connections made.
- Compressed air connected to manifold.
- Compressed air regulator set to 100 psi maximum.
- Bags and cages or cartridges installed.
- Ducting slide gates set/No obstructions in ducting.
- Filter access door(s) sealed.
- Product discharge gate or rotary airlock operational.
- Blower unobstructed and operational.

**MAINTENANCE**

Donaldson Torit filters require little maintenance in most applications. Bags require cleaning or replacement on a periodic basis. The severity of the application will dictate the time interval for bag replacement.

Diaphragm and solenoid valves should be replaced. Donaldson Torit has rebuild kits and valves available for immediate delivery. (see back page for order form.)

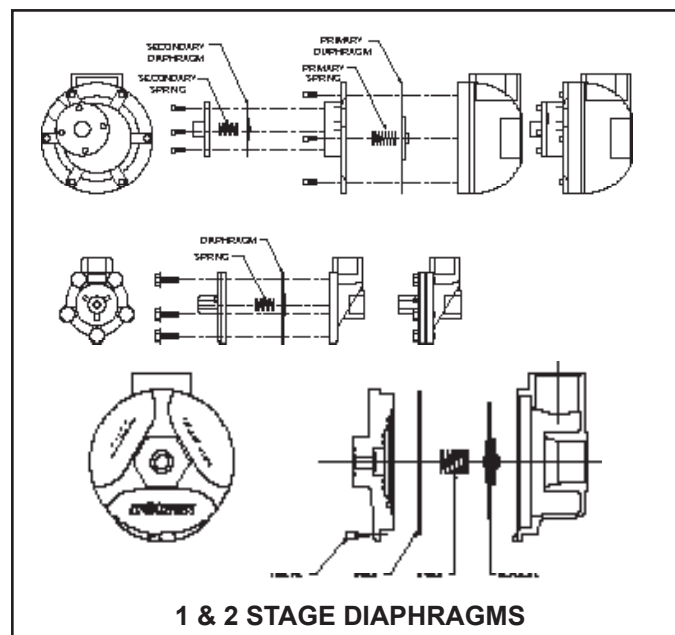

The timer sequencer is set at the factory, however can be adjusted in the field to accommodate varying loading conditions. To adjust the various settings on the timer. Open the timer box and locate the “SELECT” and ADJUST” buttons on the upper left hand side of the circuit board. Press “SELECT” until the appropriate L.E.D. is lit. Then press the “ADJUST” button until the desired value is displayed. Once all settings are at the desired values press the “SELECT” button until the “LOCKED” L.E.D. is lit. See programming example on next page.

All pulse type filters are subjected to cyclic stresses produced by the cleaning pulse. It is therefore important to inspect the filter housing for signs of fatigue as the filter ages. Bolt connections should be checked for integrity on a bimonthly basis. Also check the structural support for any signs of rust or fatigue and take appropriate steps to correct any problems.

## TIMER PROGRAMMING

Step 1) ON TIME - Press the select button until the "ON TIME" led is lit, then press the adjust button until the required on time in milliseconds is indicated. (100 milliseconds is shown)

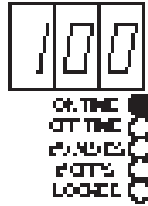

Step 2) OFF TIME - Press the select button until the "OFF TIME" led is lit, then press the adjust button until the required off time in seconds is indicated. (10 seconds is shown)

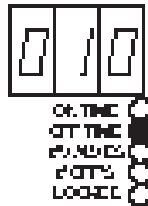

Step 3) NUMBER OF VALVES - Press the select button until the "# VALVES" led is lit, then press the adjust button until the required number of valves connected is indicated. (12 valves shown)

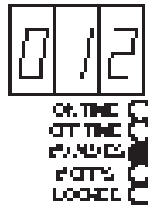

Step 4) BLOWDOWN CYCLES - Press the select button until the "OFF'S" led is lit, then press the adjust button until the required of blowdown cycles is indicated. (0 cycles is shown)

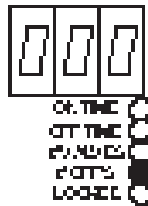

Step 5) SETTINGS LOCKED - Press the select button until the "LOCKED" led is lit. All settings are now locked. The "# OFF'S" value and led will be displayed along with the "LOCKED" led.

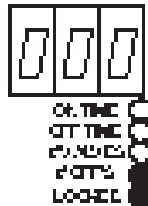

"ON TIME" settings of greater than 100 milliseconds will cause a higher rate of compressed air consumption without the benefit of additional cleaning. Do NOT exceed 100 milliseconds.

Typically timers are factory set to cycle once every two minutes therefore the "OFF TIME" can be determined by dividing 120 seconds by the number of valves.

## TROUBLESHOOTING

Occasionally problems arise in dust control systems that require attention. Following are some tips for troubleshooting typical pulse jet filter problems.

- 1) Monitor magnehelic gauge readings - in most applications the gauge will indicate 2"-4" of static pressure drop.
- 2) If pressure drop is consistently higher than 6" then the filter is either plugged or the cleaning interval is too long.
- 3) Check for excessive or unusual dust loading at the dust source.

Check for proper flow at product discharge flange on filter hopper.

Check for adequate air supply to manifold.

Check diaphragm valves operation.

Check timer interval.

- 4) If the pressure drop is consistently below 2" then the cleaning interval can be lengthened or there is a broken bag. Usually a broken bag will be accompanied by excess particulates in the exhaust air stream.
- 5) Check exhaust air stream for excess particulates. If found, shut filter system down and check for broken bag(s). Follow confined space procedures whenever servicing filter.

CAUTION

**PERMIT - REQUIRED  
CONFINED SPACE  
DO NOT ENTER**

Check dust source for unusually low dust loading.

Check timer interval.

PHOTOCOPY THIS FORM

# PARTS ORDER FORM

MAIL TO: Donaldson Torit  
 Customer Service  
 5300 Claus Road  
 Riverbank, CA 95367

OR

FAX TO: (209)-869-0258

CUSTOMER NAME: \_\_\_\_\_

SHIPPING ADDRESS \_\_\_\_\_ BILLING ADDRESS: \_\_\_\_\_

MODEL NO. \_\_\_\_\_

SERIAL NO. \_\_\_\_\_

DESCRIPTION	QTY	DESCRIPTION	QTY
<input type="checkbox"/> BAG, BOTTOM REMOVAL, 4 FT.	<input type="checkbox"/>	<input type="checkbox"/> CAGE, BOTTOM REMOVAL, 4 FT.	<input type="checkbox"/>
<input type="checkbox"/> BAG, BOTTOM REMOVAL, 6 FT.	<input type="checkbox"/>	<input type="checkbox"/> CAGE, BOTTOM REMOVAL, 6 FT.	<input type="checkbox"/>
<input type="checkbox"/> BAG, BOTTOM REMOVAL, 8 FT.	<input type="checkbox"/>	<input type="checkbox"/> CAGE, BOTTOM REMOVAL, 8 FT.	<input type="checkbox"/>
<input type="checkbox"/> BAG, BOTTOM REMOVAL, 10 FT.	<input type="checkbox"/>	<input type="checkbox"/> CAGE, BOTTOM REMOVAL, 10 FT.	<input type="checkbox"/>
<input type="checkbox"/> BAG, BOTTOM REMOVAL, 12 FT.	<input type="checkbox"/>	<input type="checkbox"/> CAGE, BOTTOM REMOVAL, 12 FT.	<input type="checkbox"/>
<input type="checkbox"/> BAG, TOP REMOVAL, 4 FT.	<input type="checkbox"/>	<input type="checkbox"/> CAGE, TOP REMOVAL, 4 FT.	<input type="checkbox"/>
<input type="checkbox"/> BAG, TOP REMOVAL, 6 FT.	<input type="checkbox"/>	<input type="checkbox"/> CAGE, TOP REMOVAL, 6 FT.	<input type="checkbox"/>
<input type="checkbox"/> BAG, TOP REMOVAL, 8 FT.	<input type="checkbox"/>	<input type="checkbox"/> CAGE, TOP REMOVAL, 8 FT.	<input type="checkbox"/>
<input type="checkbox"/> BAG, TOP REMOVAL, 10 FT.	<input type="checkbox"/>	<input type="checkbox"/> CAGE, TOP REMOVAL, 10 FT.	<input type="checkbox"/>
<input type="checkbox"/> BAG, TOP REMOVAL, 12 FT.	<input type="checkbox"/>	<input type="checkbox"/> CAGE, TOP REMOVAL, 12 FT.	<input type="checkbox"/>
<input type="checkbox"/> CARTRIDGE, BOTTOM REMOVAL 1.0 M	<input type="checkbox"/>	<input type="checkbox"/> CARTRIDGE, TOP REMOVAL 1.0 M	<input type="checkbox"/>
<input type="checkbox"/> CARTRIDGE, BOTTOM REMOVAL 1.5 M	<input type="checkbox"/>	<input type="checkbox"/> CARTRIDGE, TOP REMOVAL 1.5 M	<input type="checkbox"/>
<input type="checkbox"/> CARTRIDGE, BOTTOM REMOVAL 2.0 M	<input type="checkbox"/>	<input type="checkbox"/> CARTRIDGE, TOP REMOVAL 2.0 M	<input type="checkbox"/>
<input type="checkbox"/> DIAPHRAGM VALVE, RCA20T (9 THRU 64 BAG MODELS)	<input type="checkbox"/>	<input type="checkbox"/> TIMER BOARD	<input type="checkbox"/>
<input type="checkbox"/> DIAPHRAGM VALVE, RCA45 (81 THRU 144 BAG MODELS)	<input type="checkbox"/>	<input type="checkbox"/> MAGNEHELIC GAUGE 0-10"	<input type="checkbox"/>
<input type="checkbox"/> SOLENOID VALVE, RCA3D2	<input type="checkbox"/>	<input type="checkbox"/> HI-LEVEL INDICATOR	<input type="checkbox"/>









## The Donaldson Torit Warranty

Donaldson warrants to the original purchaser that the products will be free from defects in materials and workmanship for one (1) years from the date of shipment, if properly installed, maintained and operated under normal conditions. Donaldson does not warrant against damages due to corrosion, abrasion, normal wear and tear, product modification, or product misapplication. Donaldson also makes no warranty whatsoever as to any goods manufactured or supplied by others including electric motors, fans and control components. After Donaldson has been given adequate opportunity to remedy any defects in material or workmanship, Donaldson retains the sole option to accept return of the goods, with freight paid by the purchaser, and to refund the purchase price for the goods after confirming the goods are returned undamaged and in usable condition. Such a refund will be in the full extent of Donaldson's liability. Donaldson shall not be liable for any other costs, expenses or damages whether direct, indirect, special, incidental, consequential or otherwise. The terms of this warranty may be modified only by a special warranty document signed by a Director, General Manager or Vice President of Donaldson. Failure to use genuine Donaldson replacement parts may void this warranty. **THERE EXIST NO OTHER REPRESENTATIONS, WARRANTIES OR GUARANTEES EXCEPT AS STATED IN THIS PARAGRAPH AND ALL OTHER WARRANTIES INCLUDING MERCHANTABILITY AND FITNESS FOR A PARTICULAR PURPOSE, WHETHER EXPRESS OR IMPLIED ARE HEREBY EXPRESSLY EXCLUDED AND DISCLAIMED.**

## Parts and Service

For genuine Donaldson Torit replacement filters  
and parts, call the Parts Express Line

**800-562-0072**

**[www.donaldsontorit.com/lmcwest](http://www.donaldsontorit.com/lmcwest)**

For faster service, have unit's model and serial number,  
part number, description, and quantity available.



**Donaldson**<sup>®</sup>  
*Filtration Solutions*

Donaldson Company, Inc.  
Industrial Air Filtration  
P.O. Box 1299  
Minneapolis, MN 55440-1299  
[donaldsontorit@donaldson.com](mailto:donaldsontorit@donaldson.com)

Donaldson Company, Inc. is the leading designer and manufacturer of dust, mist, and fume collection equipment used to control industrial-air pollutants. Our equipment is designed to help reduce occupational hazards, lengthen machine life, reduce in-plant maintenance requirements, and improve product quality.